

TRANSCEND SURFACE MOUNT

FOR UP TO 75" TV

- 31.8" Of Downward Travel
- TV Maximum Screen Size: 75"
- Maximum Weight: 125 lbs.
- 4 Different Swivel Settings

The Transcend Surface is the most advanced pull-down mount available. Precision engineered suspension and dual counterbalance pistons suspend up to a 75" screen in mid-air at the optimal viewing height. The Transcend Surface's slim profile allows the screen to rest only 5.6 inches off the mounting wall, while 4-way swivel and 7 degrees of forward tilt make it even more versatile.

- Industry Leading Reliability
- Easy to Install
- Ships Fully Assembled

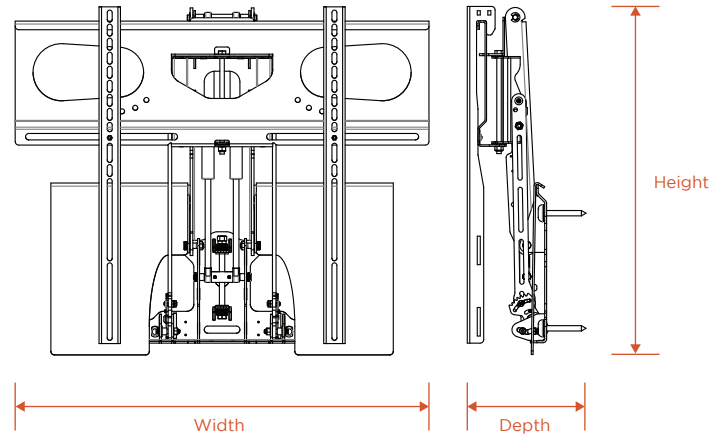

Height: 23.6"
Width: 29"
Depth: 5.6"

TECHNICAL SPECIFICATIONS

- 125 lbs. weight capacity
- TV maximum screen size: 75"
- 31.8" downward travel
- Depth from wall: 5.6", 5.1", and 4.6"
- Adjustable counterbalances for 20-125 lbs. TVs
- 0-7 degrees of tilt in the top position
- +/- 1 degree of tilt in the bottom position

WHAT'S PROVIDED

- Ready to install, assembled Transcend Mount
- Swivel Screen Back Plate
- Pair of Vertical Mounting Bars
- Two Paintable Vanity Plates
- Installation Hardware
- TV Mounting Hardware
- Cable Management Materials

ACCESSORIES

- Soundbar Mount
- Extra Wall Support

INSTALLATION TIPS

- Tip #1** Plan where to mount the system prior to making any cuts. Use Nexus' Shelf Clearance Table to properly plan your installation.
- Tip #2** Adjust the counterbalance prior to hanging the TV on the mount. Use Nexus' Instruction manual to estimate your pre-adjustment. See Nexus' Instruction manual for all adjustability provided with this mount.
- Tip #3** Attach the Vertical Mounting Bars as high as possible on the TV in order to maximize your downward travel.

Contact us for more helpful hints!



All Nexus products are shipped in custom-made protective packaging, and they include everything you need to mount and operate them. The products are designed for easy assembly, and simple instructions with photos are included.